



Modeling Renewable Electricity Generation for Northern Cyprus (TRNC)

Oluwatosin Uthman Zubair^{1*}

¹*Eastern Mediterranean University, 99628, Famagusta, North Cyprus via Mersin 10, Turkey.*

Author's contribution

The sole author designed, analyzed, interpreted and prepared the manuscript.

Article Information

DOI: 10.9734/JENRR/2021/v8i230205

Editor(s):

(1) Dr. Sreekanth K. J., Kuwait Institute for Scientific Research, Kuwait.

Reviewers:

(1) Antti Karhunen, LUT University, Finland.

(2) Ishardita Pambudi Tama, Universitas Brawijaya, Indonesia.

Complete Peer review History: <https://www.sdiarticle4.com/review-history/71318>

Review Article

Received 10 May 2021

Accepted 17 July 2021

Published 31 July 2021

ABSTRACT

Several researches have been done on modeling renewable energy for different countries and continents, employing unique approaches, strategies and methodologies. This paper aims to do the same by using the sunlight and wind resources to model a hybrid renewable energy system for the Turkish Republic of Northern Cyprus (TRNC). This paper will also carry out a comparative analysis between the modeled renewable energy generation and the present electricity generation in the country. The paper will also depict how the renewable energy relates with the country load, based on the amount of energy generated from renewable resources and the size of battery used to store excess renewable energy generated. This paper will also show how base load power plants do not allow lots of renewable energy penetration, because of the varying nature of wind and solar resources.

Keywords: *Renewable energy; photovoltaic; wind turbine; base load; base load power plant; peaking power plant.*

1. INTRODUCTION

TRNC has a great challenge in supplying enough electrical energy due to lack of fossil sources and

economic sanctions, if TRNC can make utmost use of the renewable energy source(s) available on the island, they might have a solution to their electrical energy supply. One of the biggest

*Corresponding author: E-mail: uthmanzubair@gmail.com;

challenges for governments especially in developing countries is convincing people to efficiently use electrical energy. Energy saving and environmental protection against greenhouses are the major goals that countries are looking for. The electricity demand is rising and consequently, this causes a great pressure to the economy and other infrastructures. Building of new power plants, extraction of energy from renewable energy sources or saving of energy can be considered to overcome this extra demand.

The reason for this perceived unsustainability in the use of fossil-fuels is the ever-increasing global population. As the population increases, so does the world's energy demand, which impels us to continuously plunder the finite resources of the Earth, and in so doing, adversely affects its environmental conditions. Besides the Earth's resources continuing to diminish, several other problems emanate from the use of fossil-fuels in meeting the world's energy demand, carbon emissions have continued to increase annually and now represent one of humanity's gravest existential threat. Carbon emissions already have an adverse effect on the air we breathe, most of the world's major industrial cities already suffer greatly from air-pollution as a consequence of this. Moreover, nuclear energy has not turned out to be a viable alternative neither. It is extremely expensive and it comes with even greater risks than those posed by fossil-fuel burning. In addition, both uranium and plutonium are also resources that will ultimately be depleted, and there is yet no solution to the nuclear-waste disposal challenge [1,2,3,4,5,6].

Renewable energy alone holds the promise of sating the global energy demand. However, renewables are yet having numerous challenges that must be addressed. Political and economic advocates for fossil-fuel sources continue to emphasize the unreliability of renewable sources due to their unpredictability. At present, this criticism is justified. Also, the advocates of fossil energy are pursuing two main targets: firstly, they want to preserve the energy monopoly, meaning the energy market will be controlled by a few large enterprises. Secondly, they want to preserve the coal, nuclear and gas power plant. In a nutshell, the so-called turnaround in the energy policy is definitely losing some of its momentum, we shouldn't let such happen [7, 8].

According to the 2013 post carbon pathways report, which review many international studies,

the key roadblocks are; climate change denial, the fossil fuels lobby, political inaction, unsustainable energy consumption, outdated energy infrastructure, and financial constraints [9, 10].

The high cost of electricity in TRNC and sometimes electricity outbreak during summer triggered the cause of this study. The computer software used in this study is Excel spread sheet which was used to analyse various data.

2. GEOGRAPHY AND HOUSING OF TRNC

Turkish Republic of Northern Cyprus (TRNC) is de facto independent republic located on the Mediterranean island of Cyprus officially the northern territory of the republic of Cyprus. Because of the sanction imposed on TRNC, the territory is only recognized by turkey, and TRNC depends on Turkey for military, political and economy supports. [11, 12, 13]

TRNC amount to around a third of the island, with an area of 3,355 square kilometers (1.295sqmi), Turkey lies 75kilometer (47mi) to the north. TRNC lies between latitude of 34° and 36°N, and longitude of 32° and 35° E. Since TRNC belongs to an island it has a coast which consist of enchanting coves, rocky coast and long golden sandy beaches, these beaches are among the cleanest and safest in the Mediterranean. Between May and October, the average water temperature is around 24°C [14, 15].

Cyprus is situated in the location known as the Cyprian Arc. The precise location of this Arc remains widely debated as various studies have produced differing findings. At this moment, no one is certain as to what type of fault the Cyprian Arc is [14, 16].

TRNC most notable landmark is perhaps the northern mountain range, otherwise called the Kyrenia Mountains, or the Five Finger Mountains. A rugged mountainous range running about 130 km parallel to the coastline. It occupies an area roughly 260 sq km, and primarily comprises limestone, dolomite, and marble. This range peaks at Mount Selvili, close to Lapta, at 1,023 m [13].

North Cyprus' largest spring is situated in this range close to the Kyrenia Mountains. The very rich northern coast is mostly filled with olive and carob trees [12].

The Mesaoria plain is situated in the center of the island, between the five-finger Mountains and the Southern Troodos Mountains, it is pivotal to the cultivation of important crops like wheat, barley and oats. This region is thus termed “the breadbasket of Cyprus” [14].

The north and eastern shores of North Cyprus are bounded by the beautiful Mediterranean Sea. The coastline is littered with beautiful beaches which attract tourists from all over the world, especially in the long Cyprus Summers. Guzelyurt and Famagusta have impressive bays, while Zafer, Korucam and Kasa remain attractive peninsulas [12,17].

Cyprus retains many imprints of several civilizations under whose influence the island has thrived. The island yet contains several Roman villas and theatres, as well as Byzantine cathedrals and monasteries, medieval castles, Ottoman Mosques and various other pre-historic habitats. Cyprus' major economic activities include tourism, textile and craft as well as merchant shipping. Other traditional crafts include embroidery, pottery and copper work [18].

2.1 Climate and Housing in TRNC

TRNC is generally very sunny. On average, the hours of bright sunshine over the course of the year are measured at 75% of the time the sun is over the horizon. During the six summer months, bright sunshine averages 11.5 hours per day, during the winter, this drops to about 5.5 hours. These rank among the longest periods of sunshine in the world and the solar intensity also ranks among the greatest. Solar energy has been exploited in the TRNC for several years, although only for minimal electricity generation [13,19].

Currently, the method for construction of houses implemented throughout TRNC is of the structure of a typical multi-storey and single-storey building, is made up of the foundations, the columns, the beams and slabs. All the structures make use of reinforced concrete [20,].

The walls are typically built with hollow bricks, cemented with plaster on either side. The external walls typically are about 25 cm in width, while the internal walls are about 15 cm wide. More recently, there has been a trend to use cavity external walls, generally, this consists of two brick walls with an insulated layer of about 5

cm in-between. The floors consist of concrete slabs, all covered with a layer of sand or screed about 10 cm in which all plumbing and other services are placed. The floor finishing is made up of a layer of mortar covered with tiles, marble, or granite blocks [21].

Flat roofs are made up of a slab, typically about 150 mm in width, with an added layer of plaster of 3 cm on the underside, this is applied when the slab is not smooth. The roof is usually water-proofed with a thin layer of bitumen and painted a white or aluminum color on top. More recently, there has been a trend to use an inclined, smooth slab, with light insulation, covered with a layer of mortar and roof tiles [21].

3. RENEWABLE AVAILABILITY IN TRNC

3.1 Assessment of Renewable Energy Resources in TRNC

Exploitation of renewable energy (RE) depends mainly on the economy of the particular site applying it because most types of RE resources have fairly established technologies. Not only the feasibility cost of adequate resources that play a major role in the viability and sustainability of RE projects, but technical and environmental issues also play a major role [20].

In Barker studies on tidal energy potential, he concluded that sites which have a mean range exceeding 3m can be exploited. Furthermore, he established that none of this potential exists in the Eastern Mediterranean [22].

TRNC's lack of rivers with significant yearly flows causes the lack of hydropower opportunities. Geographically there are little or no geothermal resources and the potential for small hydro plants is very limited. Hence heat stored in rock is conveyed to the surface by means of fluid and steam [21].

TRNC biomass resources include a wide range of biomass residues, forest and agricultural, sewage water sludge, municipal solid waste and a considerable potential of energy crops, which include traditional herbaceous crops, or short rotation woody crops. It was estimated that the electricity production from biomass will be about 1.4% of the total electricity consumption in the year 2010. In addition, the installed capacity is about 0.95MW, and will be using municipal sewage to produce electricity [20].

There are some areas in TRNC with onshore wind velocity of 5-6m/s and few areas with 6.5-

7m/s. Anticyclones moving from west to east affects the wind energy utilization in TRNC, during the winter it moves from the Siberian anticyclone and during the summer it's from the low pressure created in the area of India and expanded until the area of TRNC. Sea breezes generated in coastal areas as a result of the different heat capacities of sea and land, give rise to different rates of heating and cooling; and mountain valley winds, created when cool mountain air warms up in the morning and begins to rise while cool air from the valley moves to replace it, and the flow is reverse during the night [22].

Collection of sunshine duration data at a number of meteorological stations started in 1959. From the considerations affecting the use of solar energy, the classification may be broadened to 3 zones; coastal, central plains and mountains. From statistical analysis it's shown that all part of TRNC enjoys sunny climate [21,20].

3.2 Wind Resource in Cyprus

TRNC is located at the Northern part of the island (Cyprus) and Cyprus is surrounded by the Mediterranean Sea. Its climate is characterized as two distinct seasons; the rainy season, from November to March and the long dry season from the beginning of April till the end of October, during the raining season the island is under the influence of depressions crossing the Mediterranean Sea from west to east, while in the dry season the island is subjected to the shallow low pressure through which extends from continental depression centered Asia. However, in coastal areas the local sea-breeze circulation is usually very strong due to a large differential heating between sea and land [22]. In this paper I use Larnaca data, because Larnaca is the nearest station to TRNC provinces from [22].

3.3 Solar Resource in Cyprus

On a horizontal surface the average annual solar radiation received is 1725kW/m^2 per year. Direct solar radiation is about 69% of the total amount which equals 1188kW/m^2 , and the diffuse radiation is 31% (537kW/m^2). For properly sited power plants, the annual solar potential for generation is estimated to be between 1950kW/m^2 and 2050kW/m^2 per year [21].

By utilizing this energy, Cyprus has become the highest user of solar water heaters in Europe.

The European Solar Thermal Industry Federation ranks Cyprus as the leader in installed solar collectors per capita. With more than 900,000 m^2 of installed solar collectors, there is the potential to produce almost 700,000 kWh of thermal energy. Using these systems Cyprus has more than double the number of installed solar thermal collectors and produces twice the energy of Austria which is the next European user [22].

It can be observed that in summer, solar time is from 6am until 6pm and the global horizontal radiation peaks midday at up to 1000W/m^2 [20].

It is observed that global horizontal solar radiation levels are the lowest at around $\sim 450\text{W/m}^2$ during winter season. However, the radiation levels steadily increase approaching to summer season and peaks in June/July at around $\sim 950\text{W/m}^2$. This steady pattern of solar radiation that this creates constitutes as a predictive resource to be exploited via solar energy conversion systems. On the other hand, from the sudden drops in the radiation levels on the plot, it can be observed that during the winter, spring and autumn seasons the weather is cloudier compared to summer season (June, July and August). This however, requires more extensive weather forecasting tools or weather monitoring systems for large solar energy conversion systems. Clouds in the sky creating partial shadows on photovoltaic systems or blocking direct beam radiation for concentrated solar systems will lower the performance or overall output of the solar energy conversion system [22].

4. The PROPOSED MODEL AND RESULTS

4.1 The Proposed Model

This work is proposing TRNC to make use of wind energy alongside with solar energy (hybrid system) to meet most of their energy demand, Fig. 1 bellow illustrates the current electricity generation in TRNC, and Fig. 2 shows the block diagram of the proposed energy system.

Currently TRNC already has a photovoltaic power plant located at Serhatköy with capacity of 1.2MW, it's obvious that this is a very small amount of renewable energy that is in use, this paper is suggesting to increase the photovoltaic power plant and build a wind farm with it, so as to make utmost use of these two renewable sources (solar and wind). It is known that solar

energy has a very high potential in TRNC compared to wind, but using one of the renewable energies might lead to a large battery size requirement. A hybrid system with proportional system size for each energy source is needed (i.e. using significant amount of solar and wind), this will help in reducing the size of the battery.

In Fig. 1 it can be seen that TRNC uses baseload power plant as part of their electricity generation, while in Fig. 2 it is proposed that baseload power plant should be abolished since it does not allow lots of renewable energy penetration which will be shown in the following figures in Section IV(B).

5. RESULT

In this section the result of the model is shown for two different scenarios investigated and explanation is made for each figure. This model uses the hourly energy output from wind and solar in MWh for a year. The solar energy come from [23], while the wind energy was calculated based on the wind speed from [23], using equation (1).

$$P = 1/2 \rho A V^3 C_p \tag{1}$$

$$A = \pi r^2 \tag{2}$$

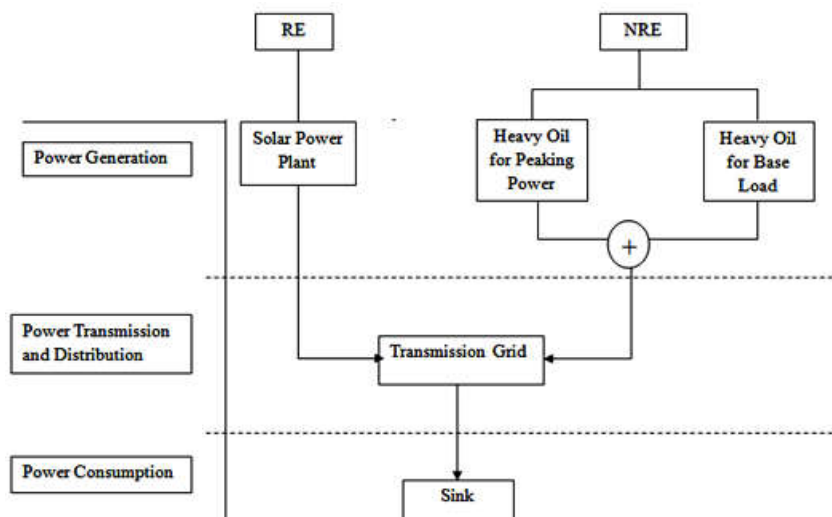

Fig. 1. Block Diagram of Current Electricity Generation System in TRNC

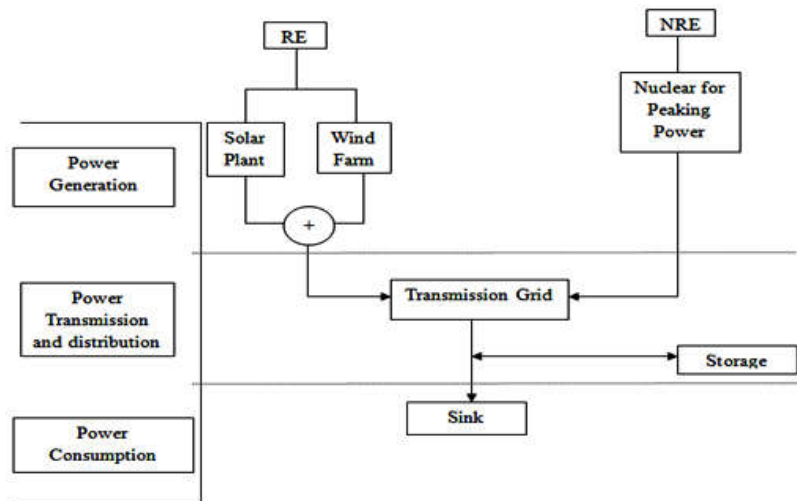
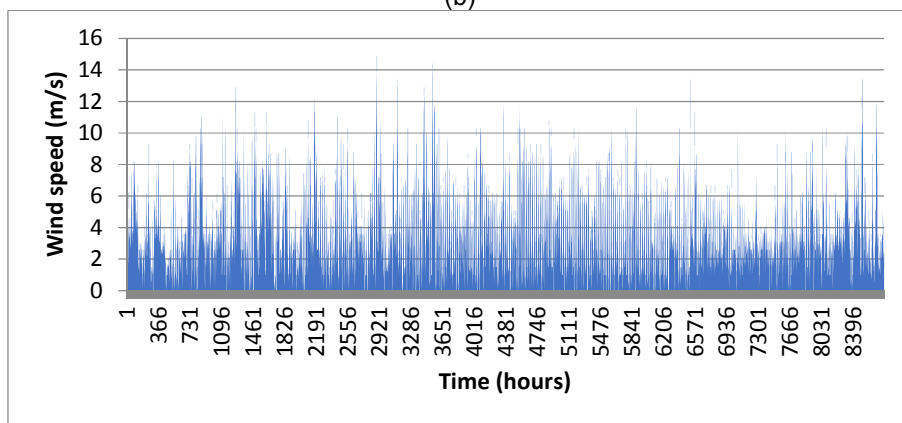
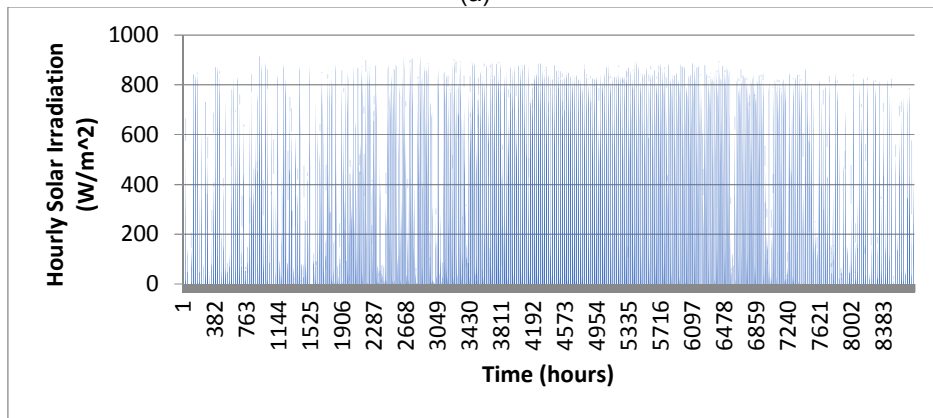
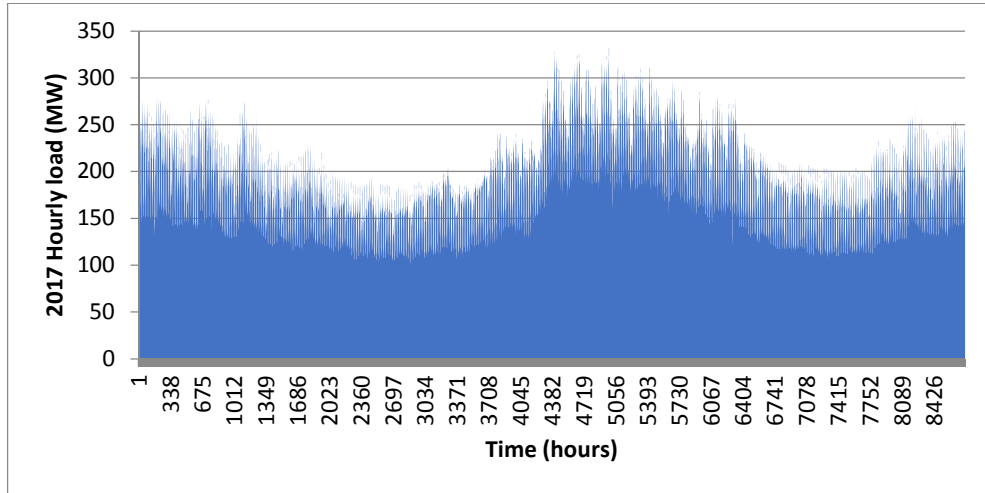
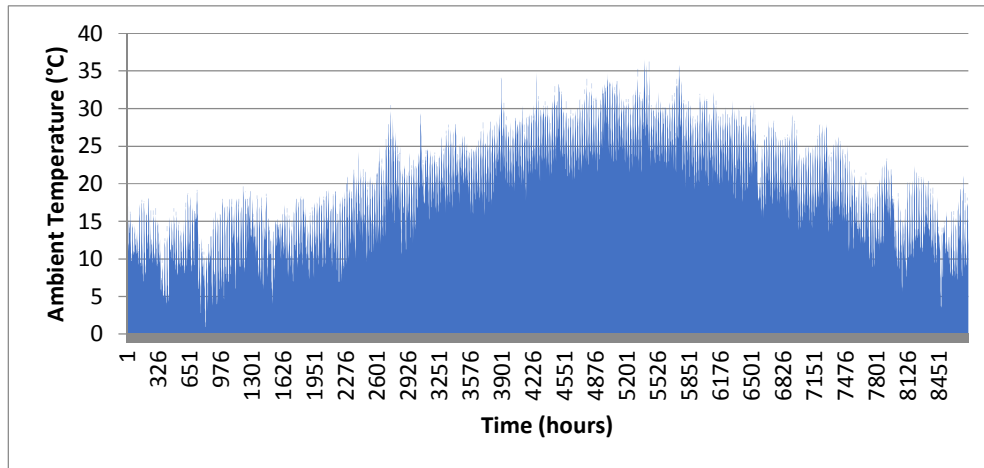

Fig. 2. Block Diagram of The Proposed Electricity Generation System

Table 1. Parameters Used to Calculate Wind Energy

Parameters	Values
ρ	1.22Kg/m ³
R	35.36m
C_p	0.4
π	3.14





(d)

Fig. 3. TRNC Annual Load and Meteorological Conditions Used in Modeling. (a) 2017 Load (b) Beam Irradiance (c) Wind Speed and (d) Ambient Temperature

We cannot see electricity itself but to understand electricity it's very helpful to see a picture and the way to do so is by modeling. Why model? We model so we can quickly try many mixes of electricity generation to find which mix works based on assumptions made.

This model takes into account a solar power plant and a wind farm. Two scenarios are considered and or investigated in this model, first scenario is renewable with baseload generation, and the other is renewable with no baseload, so as to see how baseload does not allow lots of renewable penetration.

The following mathematical equations and logical statements will help in order to understand the methodology and the results giving in the tables.

$$\text{wind scaled RE (MWh)} = \frac{\text{wind installed capacity (MW)} \times \text{wind energy (MWh)}}{\text{name plate (MW)}} \quad (1)$$

•ESB is calculated with the following nested if statement

```

if
{
(((REG + baseload) - load) > 0)
if
(ASB > ((REG + baseload) - load))
{
ESB = (REG + baseload) - load;
}
Else
{
ESB = ASB;
}

```

$$\text{solar scaled RE (MWh)} = \frac{\text{solar installed capacity (MW)} \times \text{solar energy (MWh)}}{\text{name plate (MW)}} \quad (2)$$

$$\text{REG (MWh)} = \text{wind scaled RE (MWh)} + \text{solar scaled RE (MWh)} \quad (3)$$

$$\text{Annual REG (MWh)} = \sum_{n=1}^{8760} (\text{REG}) \quad (4)$$

If $[\text{Load (MWh)} - \text{REG (MWh)}] > 0$ energy is being drawn from the battery, if there is no energy stored in the battery at that hour, backup will be in use.

If $[\text{Load (MWh)} - \text{REG (MWh)}] < 0$ the remaining energy generated at that hour will be stored in the battery if there's available space in the battery.

```

}}
Else
{
ASB=0;
}

```

• **RE Used (MWh) is calculated using the following if statement**

```

if ((load + ESB) - (REG + EDB) < 0)
{
RE Used (MWh) = (load + ESB);
}
Else
{
RE Used (MWh) = REG;
}

```

$$\text{Annual RE used (MWh)} = \sum_{n=1}^{8760} \text{RE Used (MWh)} \quad (5)$$

• **The percentage of annual RE used (MWh) is calculated with the following if statement**

```

if (annual load=0)
{
Annual RE used (%) = 0;
}
Else
{
Annual RE used (%) = \frac{(Annual RE used (MWh))}{(Annual load (MWh))} \times 100
}

```

$$\text{Annual RE over generated (MWh)} = \text{Annual RE generated} - \text{Annual RE used} \quad (6)$$

• **The percentage of annual RE over generated (MWh) is calculated with the following if statement**

```

If (annual load=0)
{
Annual RE over generated (%) = 0;
}
Else
{
Annual RE over generated (%) = \frac{\text{Annual RE over generated (MWh)}}{\text{Annual load (MWh)}} \times 100;
}

```

• **Energy curtailed (MWh) is calculated with the following if statement**

```

If ((load + ESB) - (REG + EDB) < 0)
{
Energy curtailed (MWh) = -[(load + ESB) - (REG + EDB)];
}
Else
{

```



```
0;
}
```

•Hours curtailed (hours) is calculated with the following if statement,

```
If (Energy curtailed>0)
{
Hours curtailed(hours)=1;
}
else
{
Hours curtailed(hours)=0;
}
```

Annual hours curtailed is the sum of all the hours curtailed, used as a counter, if we curtailed at specific hour the counter is increased by 1, else it will be zero, from the above if statement.

$$Annual\ Hours\ Curtailed\ (hours) = \sum_{n=1}^{8760} Hours\ Curtailed$$

Table 2. Input and Output for No Renewable Energy

	Scenario 1	Scenario 2	
Energy storage (Battery)	8,000	8,000	MWh
Solar Installed Capacity	0	0	MW
Wind Installed Capacity	0	0	MW
Annual Load	1,629,305	1,629,305	MWh
Annual RE Generated	0	0	MWh
Renewable Used and Useful When Net Load>0			
Annual RE Used	0	0	MWh
Annual RE Used	0	0	%
Annual RE Over-Generated	0	0	MWh
Annual RE Over-Generated	0	0	%
Annual Hours Curtailed	0	0	Hours
Peak (maximum load minus renewable)	322	322	MW
Minimum (load minus renewable)	101	101	MW
Energy Withdrawn from Storage	0	0	MWh
Baseload Generation	60	0	MWh
Annual Load	1,629,305	1,629,305	MWh
Annual Baseload	525,600	0	MWh
Net Annual Load - Baseload	1,103,705	1,629,305	MWh
Renewable Used and Useful When Net Load > Baseload (assuming baseload is 'must take')			
Annual RE Used	0	0	MWh
Annual RE Used	0	0	MWh
Annual RE Over-Generated	0	0	MWh
Annual RE Over-Generated	0	0	%
Annual Hours Curtailed	0	0	Hours

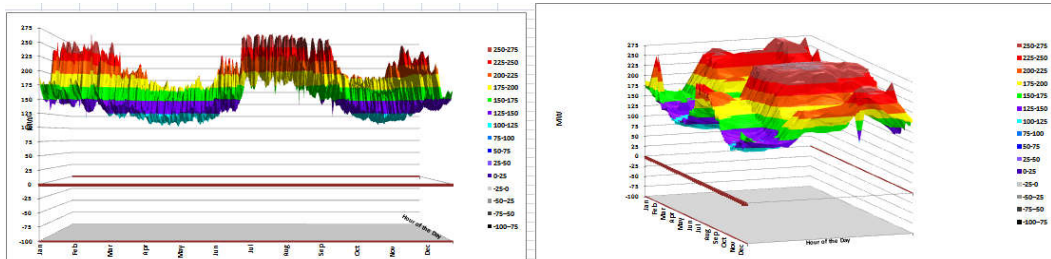

(a)

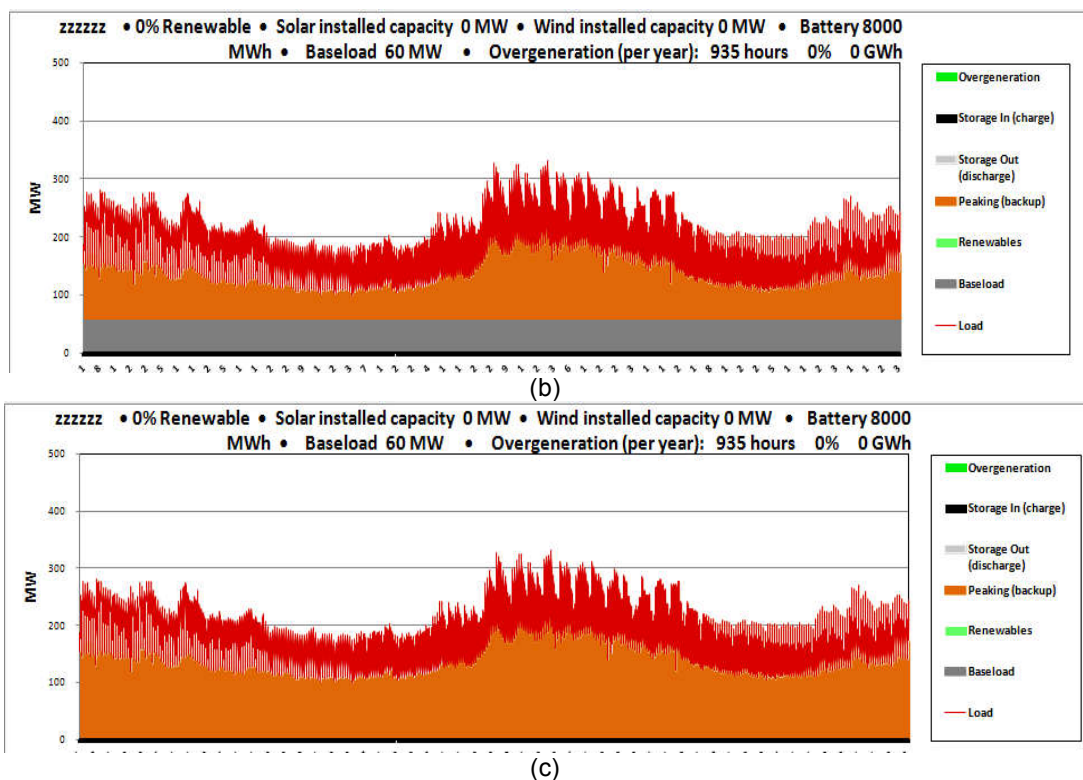

Fig. 4. Load Plot with No Renewable (A) 3-D Plot Parallel View and Elevated View (B) 2-D Plot with Baseload (Scenario1) (C) 2-D Plot with No Baseload (Scenario 2)

Table 3. Input and Output; 69% Renewable for Scenario 1 And 79% Renewable for Scenario 2

	Scenario 1	Scenario 2	
Energy Storage (Battery)	8,000	8,000	MWh
Solar Installed Capacity	800	800	MW
Wind Installed Capacity	0	0	MW
Annual Load	1,629,305	1,629,305	MWh
Annual RE Generated	1,291,641	1,291,641	MWh
Renewable Used and Useful When Net Load>0			
Annual RE Used	1,231,066	1,288,195	MWh
Annual RE Used	69	79	%
Annual RE Over-Generated	160,575	3,446	MWh
Annual RE Over-Generated	10%	0%	%
Annual Hours Curtailed	699	17	Hours
Peak (maximum load minus renewable)	278	278	MW
Minimum (load minus renewable)	-522	-428	MW
Energy Withdrawn from Storage	527,845	546,906	MWh
Baseload Generation	60	0	MWh
Annual Load	1,629,305	1,629,305	MWh
Annual Baseload	525,600	0	MWh
Net Annual Load - Baseload	1,103,705	1,629,305	MWh
Renewable Used and Useful When Net Load > Baseload (assuming baseload is 'must take')			
Annual RE Used	1,085,856	1,288,195	MWh
Annual RE Used	67	79	MWh
Annual RE Over -Generated	205,785	3,446	MWh
Annual RE Over -Generated	19	0	%
Annual Hours Curtailed	889	17	Hours

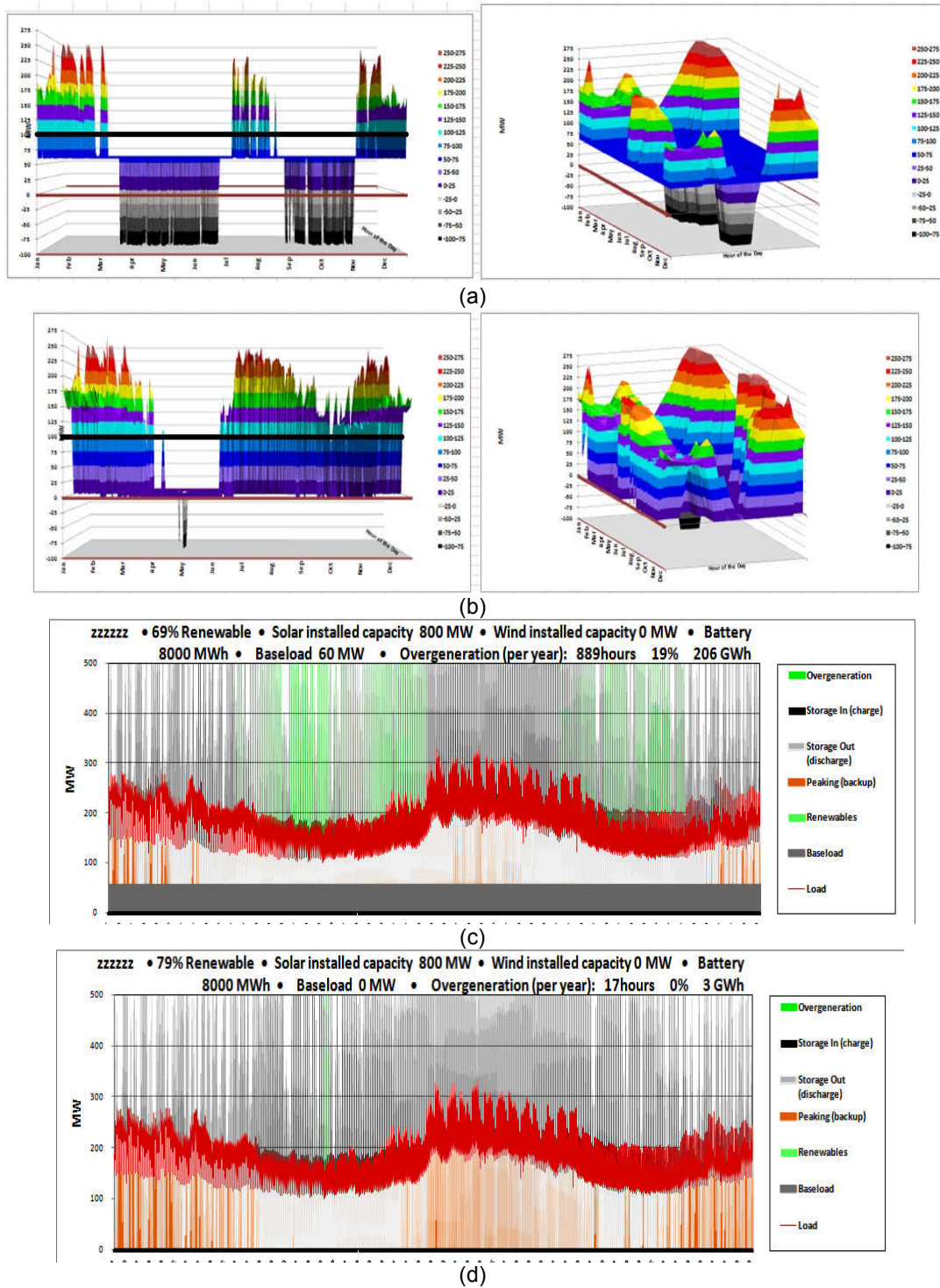

Fig. 5. Load Plot With 69% Renewable for Scenario 1 And 79% Renewable for Scenario 2. (A) 3-D Plot Parallel View and Elevated View for Scenario 1. (B) 3-D Plot Parallel View and Elevated View for Scenario 2 (C) 2-D Plot with Baseload (Scenario 1) (D) 2-D Plot with No Baseload (Scenario 2)

Table 4. Input and Output; 33% Renewable for Scenario 1 And 34% Renewable for Scenario 2

	Scenario 1	Scenario 2	
Energy storage (Battery)	8,000	8,000	MWh
Solar Installed Capacity	0	0	MW
Wind Installed Capacity	800	800	MW
Annual load	1,629,305	1,629,305	MWh
Annual RE Generated	556,873	556,873	MWh
Renewable Used and Useful When Net Load>0			
Annual RE Used	536,442	548,793	MWh
Annual RE Used	33	34	%
Annual RE Over-Generated	20,431	8,080	MWh
Annual RE Over-generated	1	0	%
Annual Hours Curtailed	54	22	Hours
Peak (Maximum load minus renewable)	311	11	MW
Minimum (Load minus renewable)	-1,219	-664	MW
Energy Withdrawn from Storage	164,058	126,872	MWh
Baseload Generation	60	0	MWh
Annual Load	1,629,305	1,629,305	MWh
Annual Baseload	525,600	0	MWh
Net Annual Load - Baseload	1,103,705	1,629,305	MWh
Renewable Used and Useful When Net Load > Baseload (assuming baseload is 'must take')			
Annual RE Used	532,878	548,793	MWh
Annual RE Used	33	34	MWh
Annual RE Over -Generated	23,995	8,080	MWh
Annual RE Over -Generated	2	0	%
Annual Hours Curtailed	68	22	Hours

It can be seen from Table 4 that with a solar system size of 0MW, wind of 800MW and battery size of 800MWh, the annual REG is 556,873MWh to meet TRNC 2017 annual load of 1,629,305MWh, also I have 0% overgeneration without using baseload, with baseload of 60MW I have 1% of overgeneration and if I assume baseload as must take energy overgeneration will increase to 2%.

Clearly, it can be seen from Table 5 that with a solar system size of 700MW, wind of 3000MW and battery size of 800MWh, the annual REG is 1,339,013MWh to meet TRNC 2017 annual load of 1,629,305MWh, also I have 2%

overgeneration without using baseload, with baseload of 60MW I have 11% of overgeneration and if I assume baseload as must take energy overgeneration will increase to 21%.

The Fig. 7(d) above is a plot of too much information in one graph, it's a plot of all the 365 days in a year, it will be nice to slide through the graph above to see the period of backups clearly, Fig. 8 below will plot 30 days interval, for a better view.

The more renewable energy penetration the narrower the peak becomes which will give room for load shifting on the DSM, Fig. 9Ta below illustrate this phenomenon better.

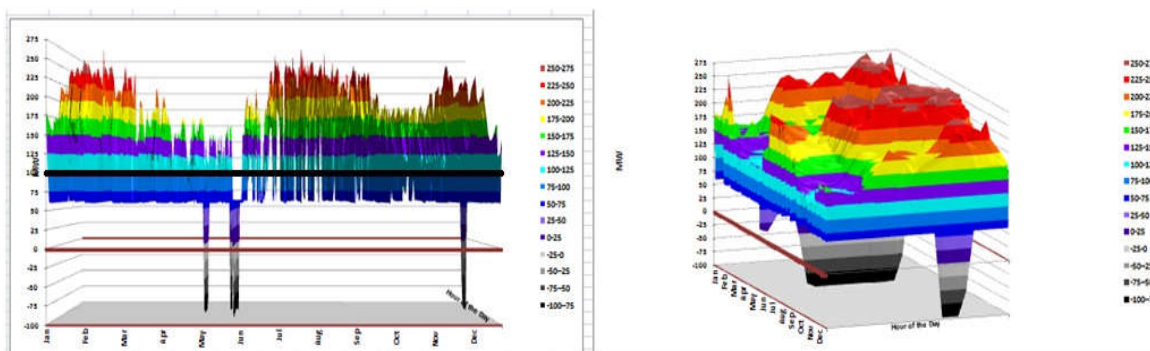

(a)

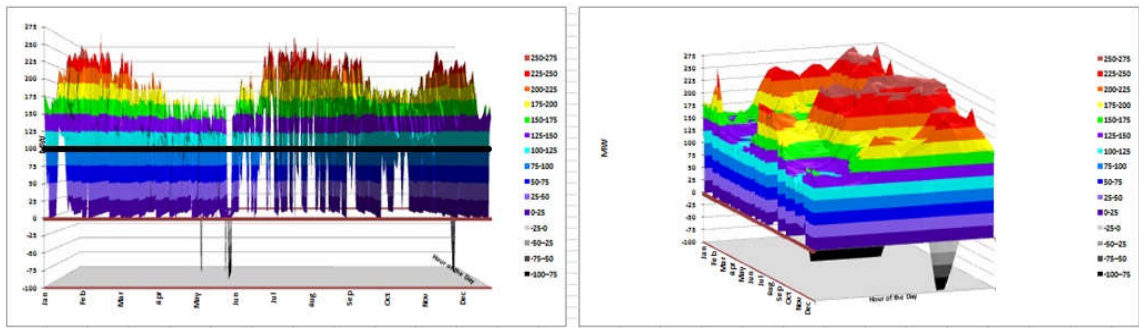

(b)

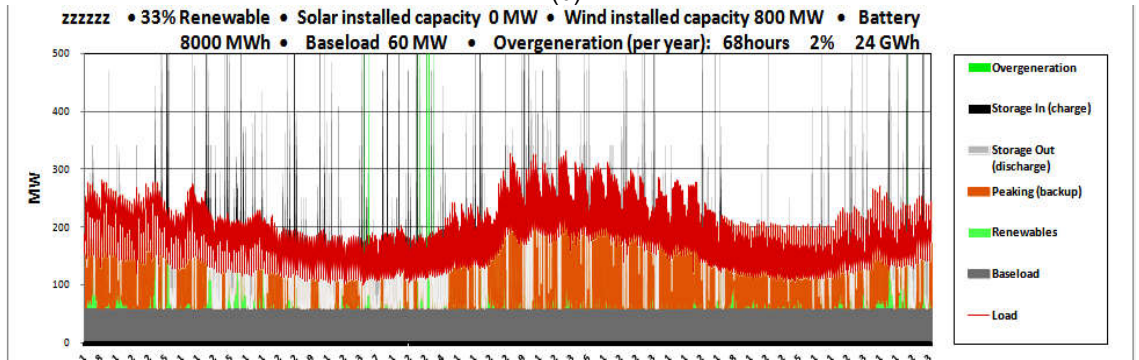

(c)

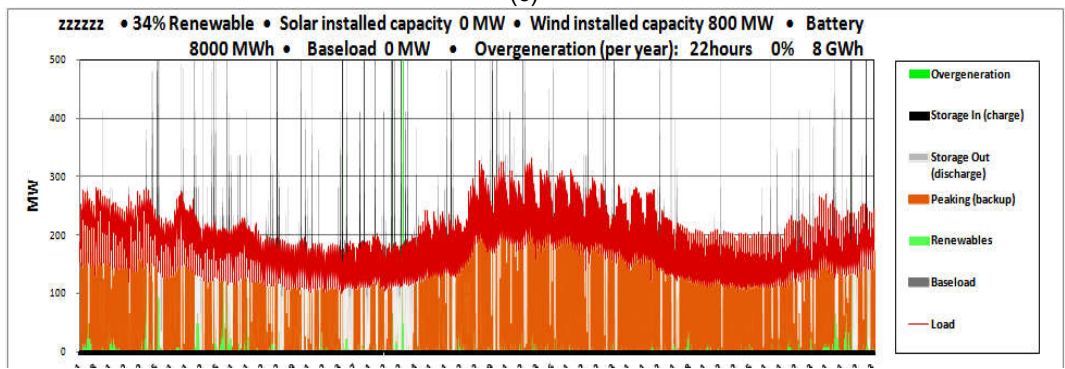

(d)

Fig. 6. Load Plot With 33% Renewable for Scenario 1 And 34% Renewable for Scenario 2. (A) 3-D Plot Parallel View and Elevated View for Scenario 1. (B) 3-D Plot Parallel View and Elevated View for Scenario 2 (C) 2-D Plot with Baseload (Scenario 1) (D) 2-D Plot with No Baseload (Scenario 2)

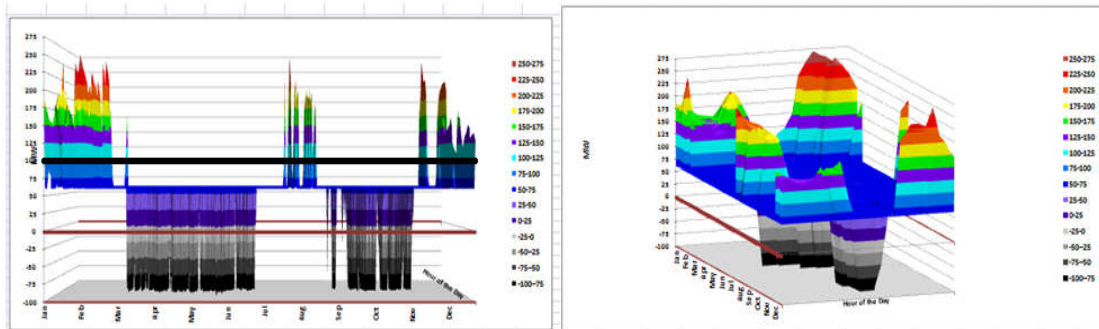

(a)

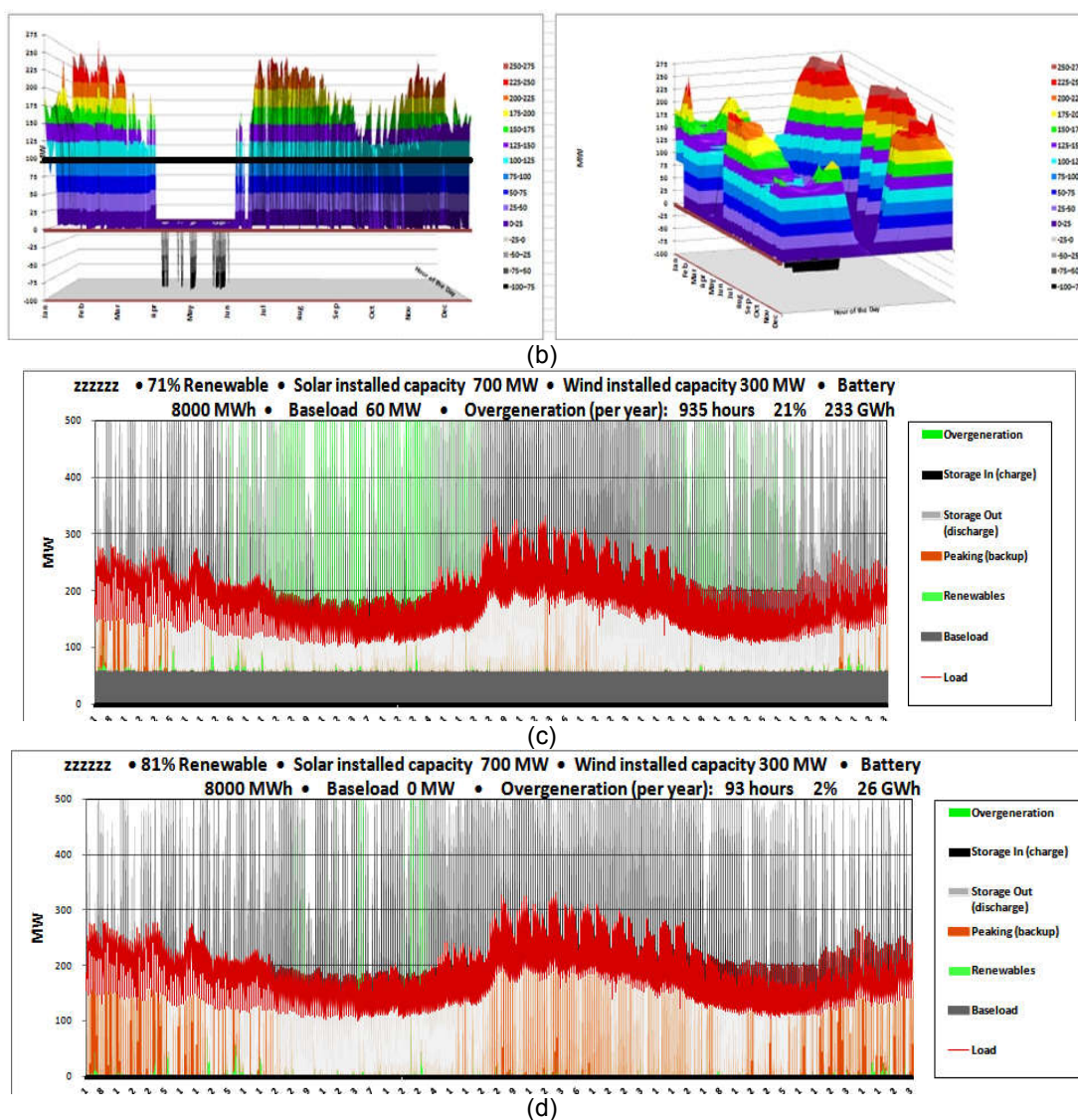
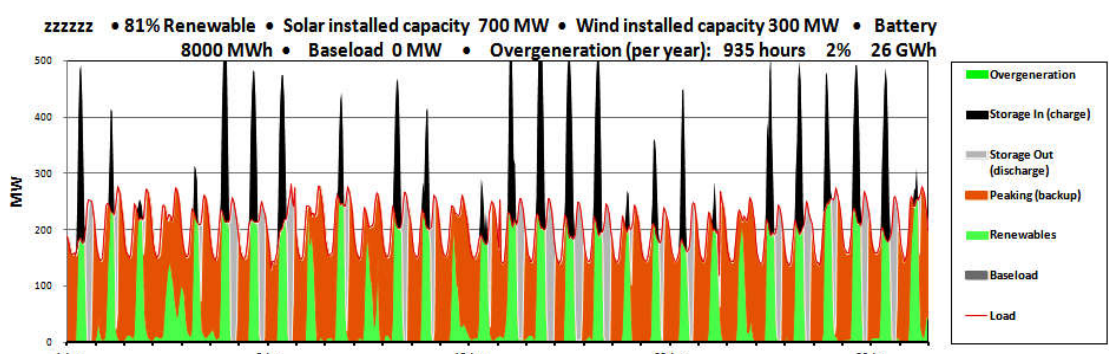

Fig. 7. Load Plot With 71% Renewable for Scenario 1 And 81% Renewable for Scenario 2. (A) 3-D Plot Parallel View and Elevated View for Scenario 1. (B) 3-D Plot Parallel View and Elevated View for Scenario 2 (C) 2-D Plot with Baseload (Scenario 1) (D) 2-D Plot with No Baseload (Scenario 2)

Table 5. Input and Output; 71% Renewable for Scenario 1 And 81% Renewable for Scenario 2

	Scenario 1	Scenario 2	
Energy storage (Battery)	8,000	8,000	MWh
Solar Installed Capacity	700	700	MW
Wind Installed Capacity	300	300	MW
Annual load	1,629,305	1,629,305	MWh
Annual RE Generated	1,339,013	1,339,013	MWh
Renewable Used and Useful When Net Load>0			
Annual RE Used	1,154,156	1,312,927	MWh
Annual RE Used	71	81	%
Annual RE Over-Generated	1884,857	26,086	MWh
Annual RE Over-generated	11	2	%

	Scenario 1	Scenario 2	
Annual Hours Curtailed	742	93	Hours
Peak (Maximum load minus renewable)	273	275	MW
Minimum (Load minus renewable)	-989	-989	MW
Energy Withdrawn from Storage	498,473	517,759	MWh
Baseload Generation	60	0	MWh
Annual Load	1,629,305	1,629,305	MWh
Annual Baseload	525,600	0	MWh
Net Annual Load - Baseload	1,103,705	1,629,305	MWh
Renewable Used and Useful When Net Load > Baseload (assuming baseload is 'must take')			
Annual RE Used	1,105,949	1,312,927	MWh
Annual RE Used	68	81	MWh
Annual RE Over -Generated	233,064	26,086	MWh
Annual RE Over -Generated	21	2	%
Annual Hours Curtailed	935	93	Hours



(a)

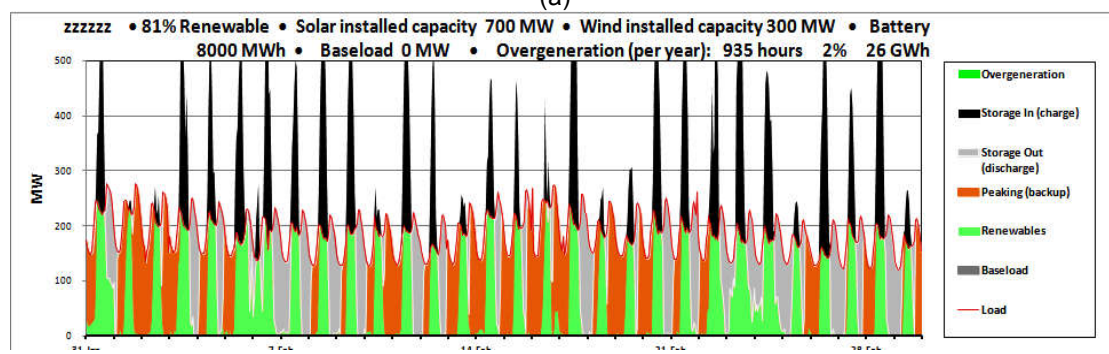

(b)

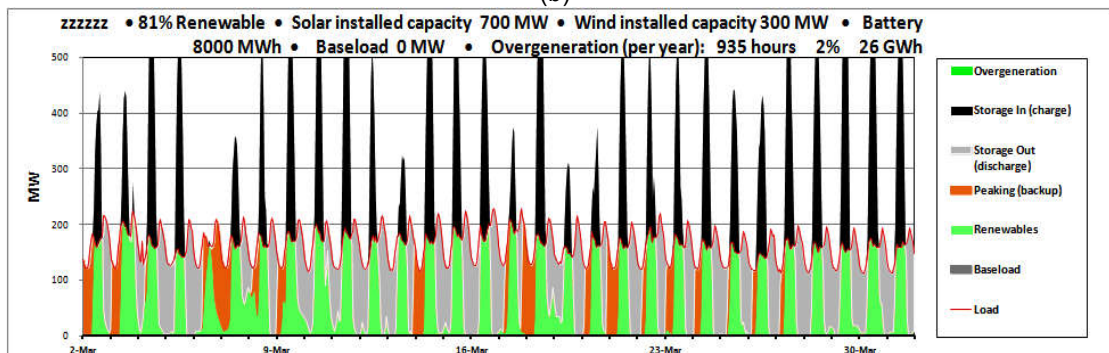

(c)

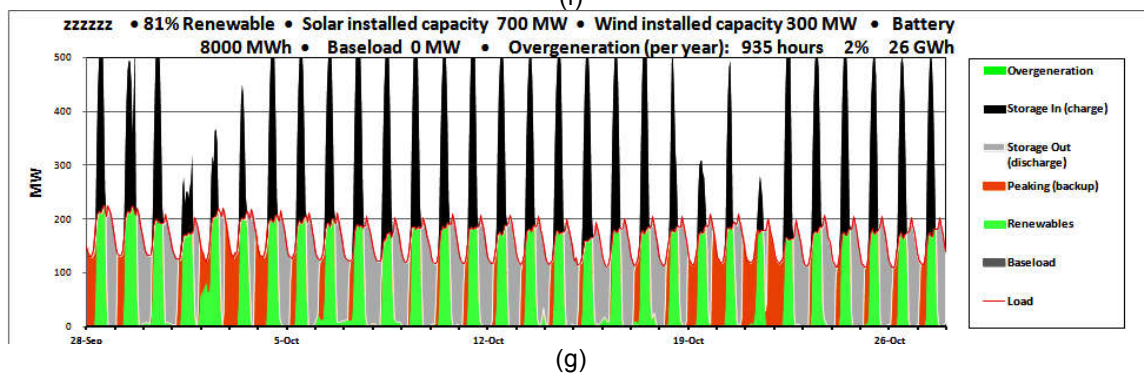
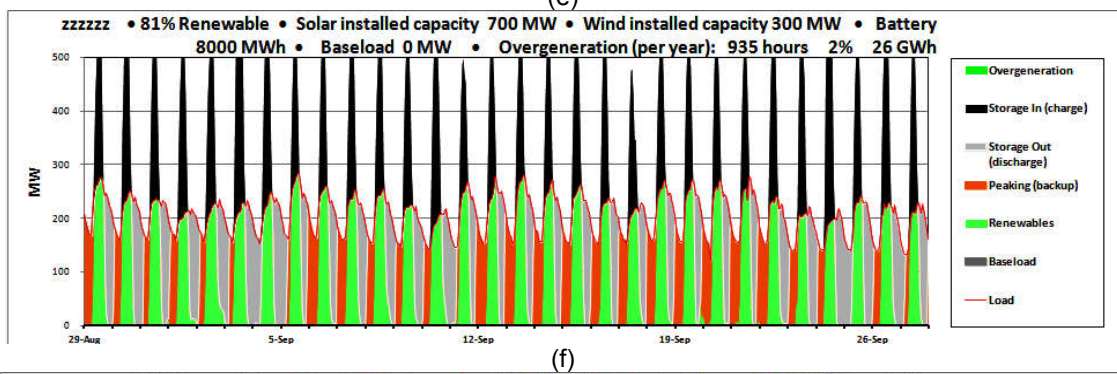
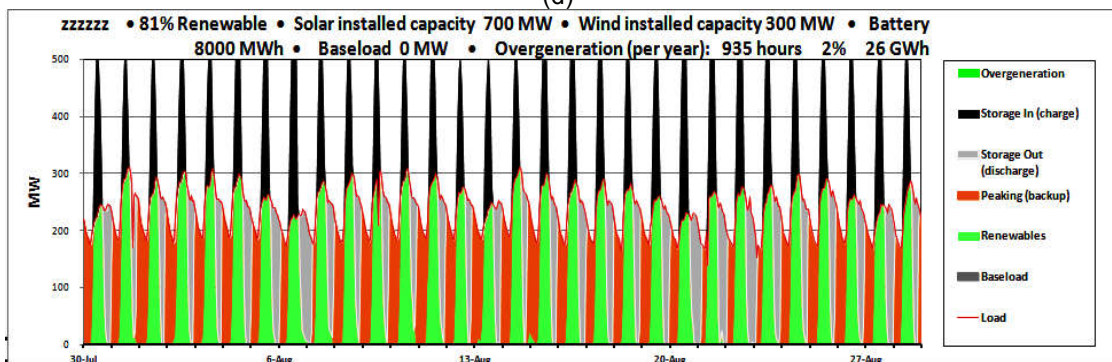
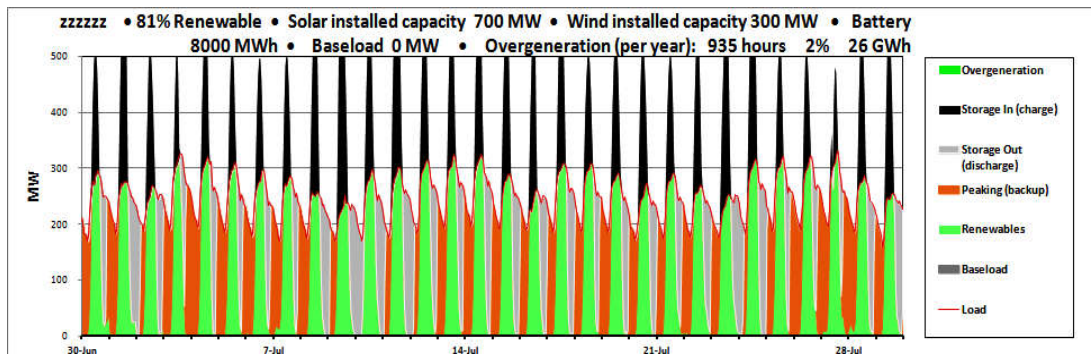

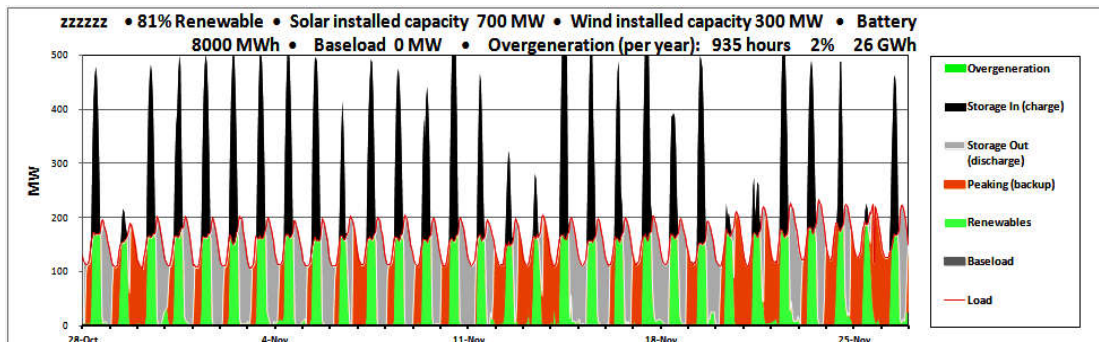

(h)

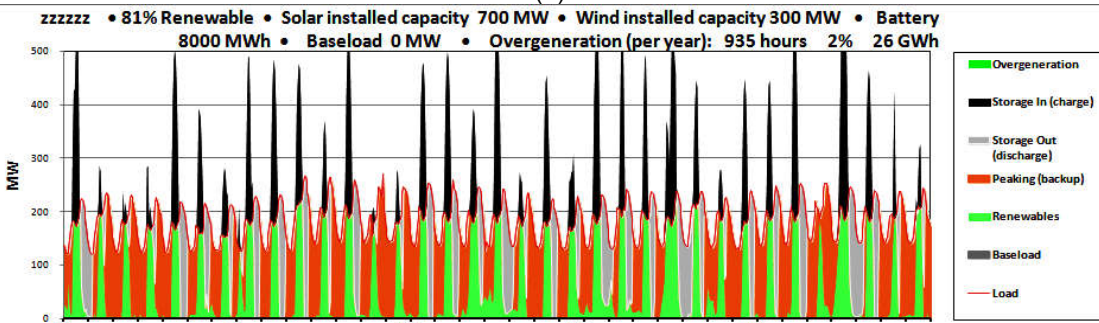

(i)

Fig. 8. Load Plot With 81% Renewable for Scenario 2. (A) From 1st of January – 30th of January (B) From 31st of January – 1st of March (C) From 2nd of March – 31st of March (D) From 30th of June– 29th of July (E) From 30th of July–28th of August (F) From 29th of August – 27th of September (G) From 28th of September – 27th of October (H) From 28th of October – 26th of November (I) From 27th of November –31st of December

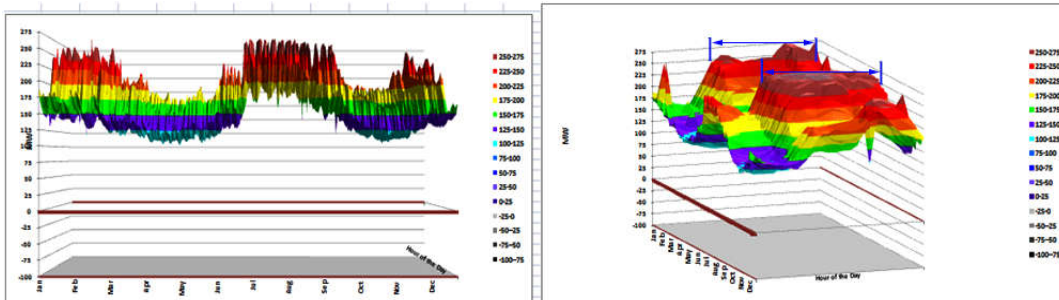

(a)

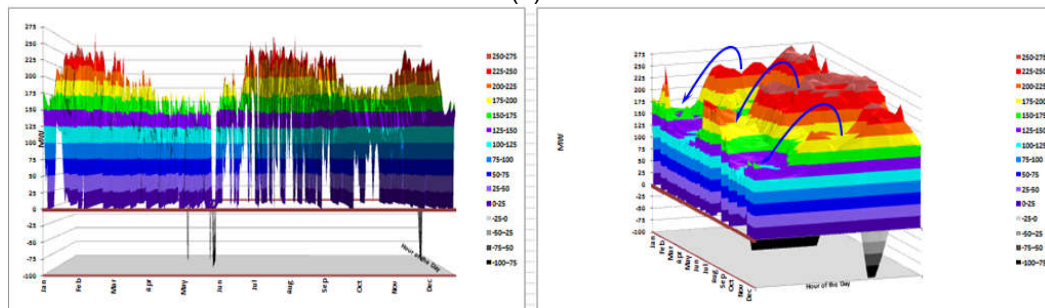

(b)

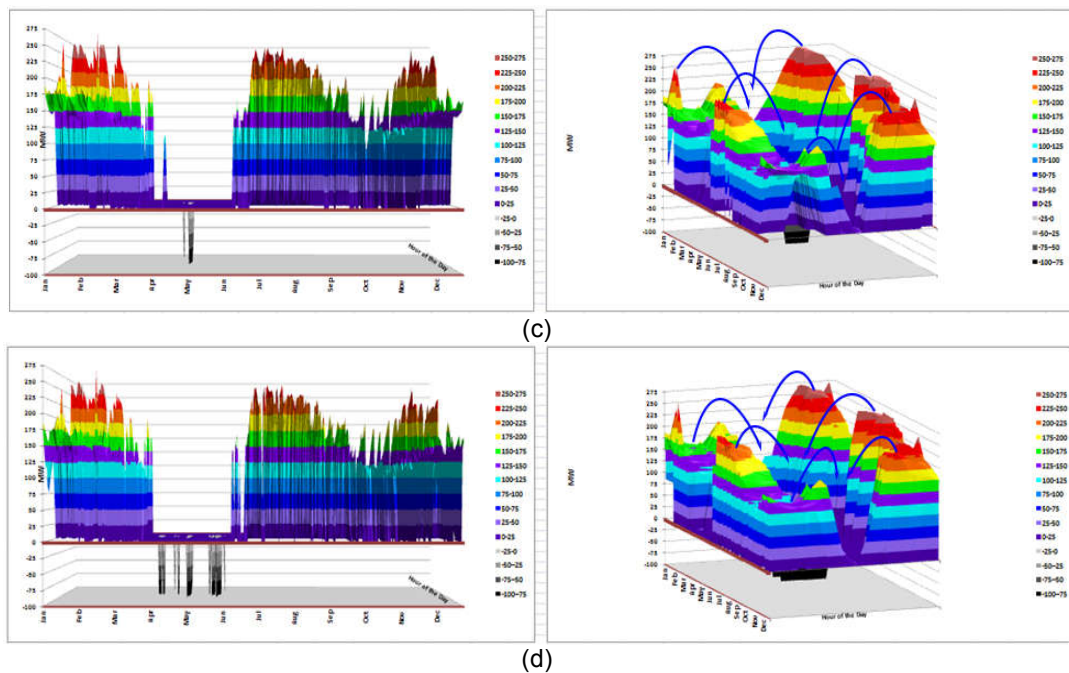

Fig. 9: 3-D Plot Parallel and Elevated View (Scenario 2). (A) 0% Renewable Energy (2017 TRNC Load) (B) 34% Renewable Energy. (C) 79% Renewable Energy. (D) 81% Renewable Energy

6. CONCLUSION

Clearly, it can be concluded that in order for TRNC to be able to make optimal use of their renewable energy resources, which can be of a better solution to their current energy challenges, they must abandon baseload generation. As it can be seen from this work, that baseload does not allow lots of renewable energy penetration, because baseload causes lots of overgeneration. And to make use of renewable there will be need to use more of the solar energy due to the high potential solar holds in this region. It can also be seen that, with installed capacity (system size) of 800MW for both solar and wind, solar generates more renewable energy compared to wind. Even though solar have numerous potentials over wind, it is still very advisable to use a hybrid system so as to reduce the battery size and also to reduce downtime when the other resources are not available. Also, it is clear that renewable electricity generation will help in demand side management. It can also be seen that the peak of the load plot with no RE is very broad, which will be very difficult for load shifting; however, penetration of renewable energy narrows the peak, the more renewable energy the narrower the peaks become. This can easily allow load shifting down the valley, which was also illustrated in the result section. The only disadvantage and challenge that TRNC might

face changing their electricity production into renewable, is the high cost of setting up a renewable energy plant.

I strongly recommend TRNC to look into using more renewable source(s) of energy in their electricity generation so as to cut low their expenses on fossil fuels, and also to reduce the negative environmental effect that fossil fuels can cause.

COMPETING INTERESTS

Author has declared that no competing interests exist.

REFERENCES

1. Dilip Ahuja, Marika Tatsutani. "Sustainable energy for developing countries", S.A.P.I.EN.S [Online], 2.1 | 2009, Online since 27 November 2009, connection on 15 January 2021. Available: <http://journals.openedition.org/sapiens/823>.
2. Choo YY, Dayou J. A Method to Harvest Electrical Energy from Living Plants. *Journal of Science and Technology*, 2013; 5(1).
3. Aliyu R. *Designing for Sustainable Communities: The Abuja Federal Capital Territory of Nigeria*; 2016.

4. Sudrajad A., June. Diesel Particulate Matter Distribution of DI Diesel Engine Using Tire Disposal Fuel. In International Conference on Engineering and Technology Development (ICETD); 2012
5. Abdullah Alhamzi BM. A study of energy scavenging strategy in a tapping tree power (Doctoral dissertation, Universiti Tun Hussein Onn Malaysia); 2014.
6. IRENA, International Renewable Energy Agency (IRENA). [online] Irena.org.; 2014. Available:<<http://www.irena.org/>> [Accessed 11 January 2018].
7. Phebe Asantewaa Owusu, Samuel Asumadu-Sarkodie | Shashi Dubey (Reviewing Editor) A review of renewable energy sources, sustainability issues and climate change mitigation, Cogent Engineering, 2016;3:1, DOI: 10.1080/23311916.2016.1167990.
8. Optimetron, The Challenge Is to Start Living in The Near Future with Much Less Combustion Energy; 2015. [online] Optimetron.com. Available:<http://www.optimetron.com/?gclid=Cj0KCQiAlpDQBRDmARIsAAW6-DPglv2u2-TM3OiwVul4nYtdaxJLAmPh5w9SD72Cu2OHa5hE9dWI3kaAv_0EALw_wcB> [Accessed 14 January 2017].
9. Wiseman J. Edwards T, Luckins K. Post carbon path ways towards a just and resilient post carbon future. [ebook] Melbourne: Centre for Policy Development; 2013. Available:<https://cpd.org.au/wp-content/uploads/2013/04/Post-Carbon-Pathways-Report-2013_Revised.pdf> [Accessed 16 October 2017].
10. Go100re.net. 2016. The Global 100% Renewable Energy Platform – Making 100% The New Normal. [online] Available at: <<http://www.go100re.net/>> [Accessed 16 January 2018].
11. Boas G. Public International Law: Contemporary Principles and Perspectives. [ebook] Cheltenham and Northampton: Edward Elgar Publishing Limited and Edward Elgar Publishing, Inc.; 2012. Available:<<https://www.researchgate.net/file.PostFileLoader.html?id=56cc58a360614b88218b457c&assetKey=AS%3A332277797146624%401456232608303>> [Accessed 16 December 2017].
12. Akgün C. The Case of TRNC In the Context of Recognition of States Under International Law. [ebook] Ankara: Ankarabar Review; 2011. Available:<http://uniset.ca/microstates2/trnc_akgun.pdf> [Accessed 19 October 2017].
13. Diana Darke, Murray Stewart. North Cyprus. Published, Bradt Travel Guides, 2015; 5 ISBN 1841629162, 9781841629162.
14. Northcyprus.co.uk. n.d. Temperatures and Seasons in North Cyprus – North Cyprus. [online] Available:<<http://www.northcyprus.co.uk/weather-and-climate-in-north-cyprus/>> [Accessed 17 February 2017].
15. Cypnet.co.uk. n.d. North Cyprus: Weather. [online] Available:<<http://www.cypnet.co.uk/ncyprus/main/weather/>> [Accessed 13 February 2017].
16. Wdowinski, S, Ben-Avraham Z, Arvidsson, R Ekström G. Seismotectonics of the Cyprian arc. Geophysical Journal International, 2006. ;164(1):176-181.
17. Pickupnorthcyprus.com. n.d. About North Cyprus. [online] Available:<<https://www.pickupnorthcyprus.com/about-north-cyprus>> [Accessed 14 April 2018].
18. Heland. The Mediterranean Region: A state of the art report on the situation of Mediterranean countries. [ebook] Qormi: Print Right Ltd.; 2015. Available:<www.jreds.org/portals/0/pdf/bookletShortversionStateoftheArt42.pdf> [Accessed 14 June 2018].
19. Northcyprus.co.uk, n.d. Temperatures and Seasons in North Cyprus – North Cyprus; 2000. [online] Northcyprus.co.uk. Available:<<http://www.northcyprus.co.uk/weather-and-climate-in-north-cyprus/>> [Accessed 14 April 2018].
20. Soyali D. An Investigation into integration of Renewable Energy Source for Electricity Generation: A case Study of Cyprus (PhD). University of Bath;2013.
21. Lapithis PA. Solar Architecture in Cyprus (Doctoral dissertation, Cardiff University).
22. Openei.org. (n.d.). Solar and Wind Energy Resource Assessment (SWERA) | Open Energy Information. [online] Available:<[https://openei.org/wiki/Solar_and_Wind_Energy_Resource_Assessment_\(SWERA\)](https://openei.org/wiki/Solar_and_Wind_Energy_Resource_Assessment_(SWERA))> [Accessed 28 May 2017].

23. Pwatts.nrel.gov. (n.d.) PVWatts Available:<http://pwatts.nrel.gov/pwatts.php>
Calculator. [online] p [Accessed 27 Jan. 2018].

© 2021 Zubair; This is an Open Access article distributed under the terms of the Creative Commons Attribution License (<http://creativecommons.org/licenses/by/4.0>), which permits unrestricted use, distribution, and reproduction in any medium, provided the original work is properly cited.

Peer-review history:
The peer review history for this paper can be accessed here:
<https://www.sdiarticle4.com/review-history/71318>